



Application

Remarks

A mechanical stop must protect the load cell against "static" overloads. The adjustment of this stop must leave a gap at least equal to the load cell's deflection under full load. The load cell must also be protected by shock absorbers against shocks, dynamic overloads or vibrations.

Mechanical installation

On metal foot

The force to be measured must be applied on the axis of the load point, without gap, inclination or torsion.

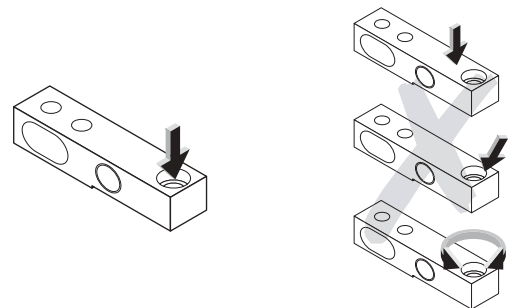

Right mounting

Right mounting

On a metal supporting structure

The load cell must be fitted on the axis of the structure.

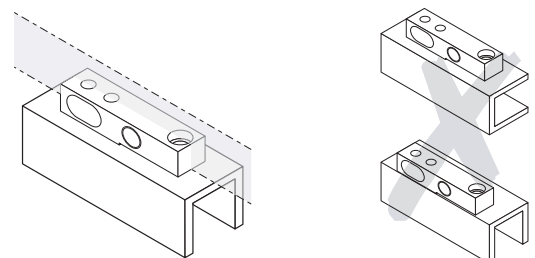

Right mounting

Right mounting

The supporting structure must be so stiff that it does not bend under the weight of the load. Reinforcement of the structure may in some cases be necessary.

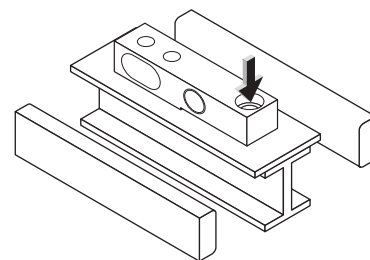

Application

- Scales.
- Tankscales, hopperscales.

Presentation

General information

The CMI load cell consists of a stainless steel strain member and is hermetically sealed by laser welded stainless steel cups.

It has been designed for use in industrial environments with an aggressive atmosphere, such as the chemical industry. CMI load cells have been test certificate for 3 000d. Meeting the IP 68 standard, CMI load cells are compact and available in four capacities: 500, 1 000, 2 000 and 5 000 kg.

Special mounting parts to adapt the load cell to its mechanical environment are available as an option.

Description

The working principle of the CMI load cell is to measure the deformation of a beam subjected to shear stress. The strain gauges are arranged to form a Wheatstone bridge, converting the mechanical force exerted on the load cell into an electrical signal.

Conformity

- Test certificate Nr. SDM 00.07 according to R60 of the OIML.

Option

Ex version for use in explosive and according to new directive 94/09/CE. EEx ia IIC T6.

CE type certificate Nr : LCIE 02 ATEX 6083 X

Wiring

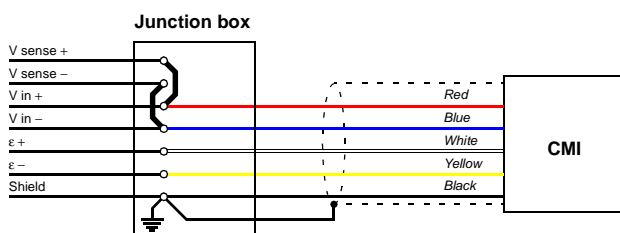

Dimensions

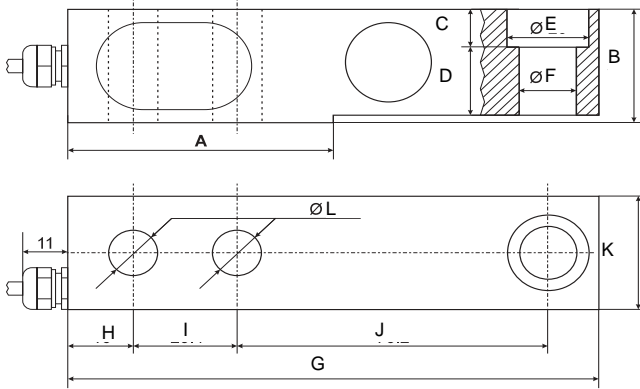

CMI	500	1000	2000	5000	CMI	500	1000	2000	5000		
A	mm	59	56	53.5	104	G	mm	130	130	130	192
B	mm	30	30	30	44	H	mm	17.4	17.4	16.4	38.6
C	mm	10	10	10	15	I	mm	25.4	25.4	25.4	38.1
D	mm	14.5	13.4	15.3	21.4	J	mm	76.2	76.2	76.2	95.3
E	mm	20	20	20	32	K	mm	30	30	30	40
F	mm	14	14	14	22	L	mm	12.3	12.3	12.3	20.5

Metrological data

CMI		500	1 000	2 000	5 000	
Nominal load	E _{max}	500	1 000	2 000	5 000	kg
Minimum load	E _{min}	5	5	20	40	kg
Minimum division	v _{min}	50	100	200	500	g
Max. number of divisions	n _{max}	3 000	3 000	3 000	3 000	

Mechanical data

CMI	500	1 000	2 000	5 000	
Maximum load	750	1 500	3 000	7 500	kg
Breaking load	1 000	2 000	4 000	10 000	kg
Deflexion under nominal load	0.3	0.6	1.2	1.1	mm
Fixation screws (not supplied)	M12x45*	M12x45*	M12x45*	M20x65**	
Tightening torque (min - max)	3.5/4	3.5/4	3.5/4	7/9	daN.m

* Minimum length = 45 mm
** Minimum length = 65 mm

Electrical characteristics

- Maximum excitation voltage ac or dc 12 V
- Input impedance 420 Ω ± 10%
- Output impedance 351 Ω ± 2 Ω
- insulation resistance > 5 000 MΩ
- Sensitivity 2 mV/V ± 0.1%
- Non-repeatability < 0.005%
- Temperature effect on sensitivity < 0.0009 % / °C
- Temperature effect on zero balance < 0.0014 % / °C
- Shielded cable, in black PVC jacket
 - O.D 4.8 mm
 - Length
 - CMI 500, 1000, 2000 3 m / 6 m
 - CMI 5000 8 m
 - Max. bending radius 20 mm

Environment

- Temperature range
 - Recommended - 10 °C / + 40 °C
 - Without alteration - 20 °C / + 60 °C
 - Storage - 25 °C / + 80 °C
 - Protection according to EN 60-529 IP 68

Options*

Hopper mounting - Shock absorber

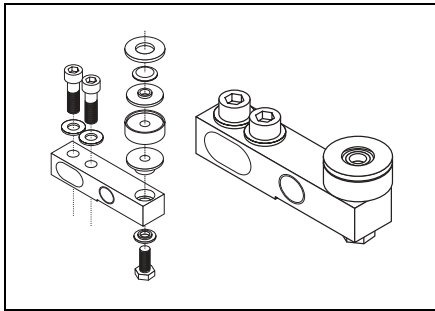

Hopper mounting - Ball bearing and stop

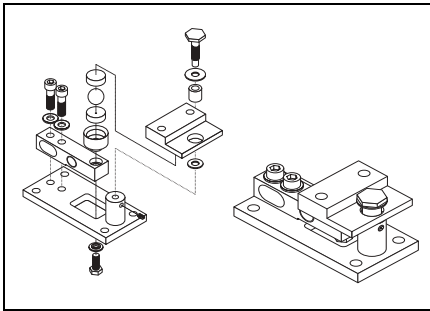

Traction mounting with rings

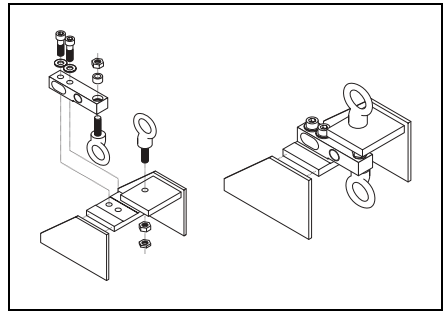

Standard marking

PRECIA MOLEN CMI A951
(modèle)
SDM N°00.07 N°XXXXXX
IP68
Fabriqué en 200X

Ex version making

CE 0081 II 1 G/D
EEx ia IIC T6
LCIE 02 ATEX 6083 X T80°C
T°amb:+60°C
PRECIA MOLEN
BP106 07000 PRIVAS FRANCE

* Arrangement may vary with each model.

Your weighing specialist

Illustrations are not contractual. Precia-Molen reserves the right to modify at any time, without prior notice, the information contained in this leaflet.

Offices and Factory
P.O. Box 106 - F 07000 Privas - France
Tel. 33 (0) 475 664 600
Fax 33 (0) 475 658 330
E-MAIL webmaster@preciamolen.com

RCS : 386 620 165 RCS Aubenas

