



Applications

- Weighing of hoppers, tanks.
- Scales.
- Renovation of scales and mechanical weighbridges.

Presentation

Description

- Fully designed in stainless steel for use in severe environments.
- Measurement of the deformation of beams by strain gauges installed in Wheatstone bridge (signal proportional to the load to be measured).
- Accuracy class : D1, C3 and C6*
- Degree of protection : IP 67
- Capacity : 10 - 20 - 50 - 100 - 200 - 500 kg

Conformity

- Certificate of conformity with recommendation OIML R60 with test certificate CE No. TC 2583.

Option

- Ex version for use in explosive area. (EEx ia II C T6 II 2 G). (IP67 T80°C II 2 D)

Different capacities of the FA 3000 i(C3)

D1

Type	Capacity	Minimum increment	Load limit	Breaking load
FA 3000 i 10	10 kg	3.6 g	15 kg	30 kg
FA 3000 i 20	20 kg	7.2 g	30 kg	60 kg
FA 3000 i 50	50 kg	18 g	75 kg	150 kg
FA 3000 i 100	100 kg	36 g	150 kg	300 kg
FA 3000 i 200	200 kg	72 g	300 kg	600 kg
FA 3000 i 500	500 kg	180 g	750 kg	1500 kg

C3

Type	Capacity	Minimum increment	Load limit	Breaking load
FA 3000 i 10	10 kg	0.9g	15 kg	30 kg
FA 3000 i 20	20 kg	1.8 g	30 kg	60 kg
FA 3000 i 50	50 kg	4.5 g	75 kg	150 kg
FA 3000 i 100	100 kg	9 g	150 kg	300 kg
FA 3000 i 200	200 kg	18 g	300 kg	600 kg
FA 3000 i 500	500 kg	45 g	750 kg	1500 kg

C6

Type	Capacity	Minimum increment	Load limit	Breaking load
FA 3000 i 50	50 kg	3.3 g	75 kg	150 kg
FA 3000 i 100	100 kg	6.6 g	150 kg	300 kg
FA 3000 i 200	200 kg	13.2 g	300 kg	600 kg

* 50, 100 and 200 kg only.

Dimensions

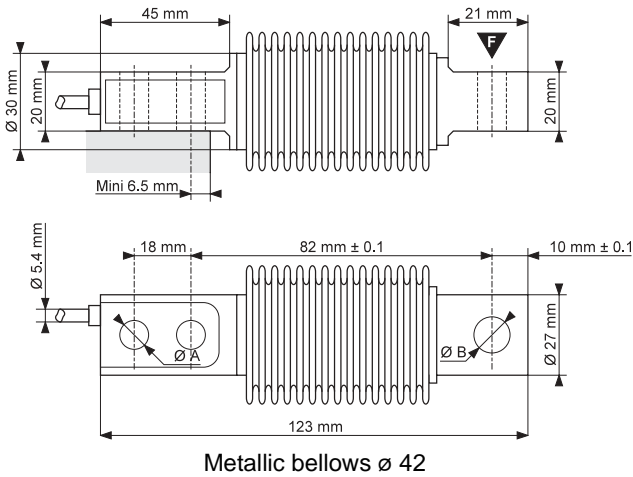

	A (mm)	B(mm)
5 à 200 kg	8,2	8,2
500 kg	10,5	11,1

Metrological characteristics

- Sensitivity 2 mV/V
- Total error..... < 0,02 %
- Non-repeatability < 0,005 %
- Temperature effect on zero balance < 0,0014 % / °C
- Temperature effect on sensitivity < 0,0009 %

Electrical characteristics

- Power supply voltage : nominal 0,5 à 12 V
- Power supply voltage : maximum 18 V
- Input impedance 350 à 390 Ω
- Output impedance 356 Ω
- Insulation > 5 000 MΩ
- Cable
 - Length 3 m
 - Colors :

Power supply+	Blue	Signal +	White
Return +	Green	Signal -	Red
Power supply -	Black	Shielding	Yellow
Return -	Gray		

Environment

- Temperature range
 - Recommended - 10 °C / + 40 °C
 - Without modification - 20 °C / + 60 °C
 - Storage - 40 °C / + 80 °C
- Sealing and protection..... IP 67

Options

■ Environment with ball

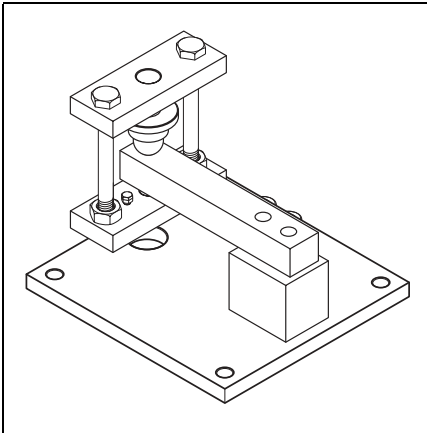

■ Environment with shock absorber

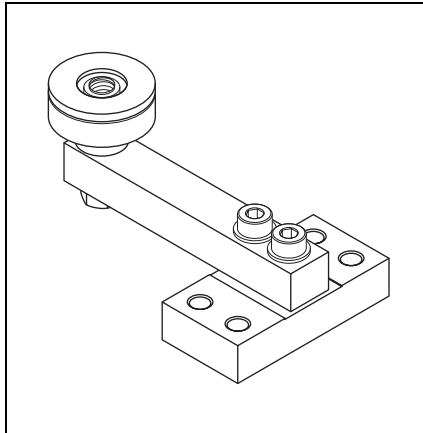

■ Environment with pulling rod

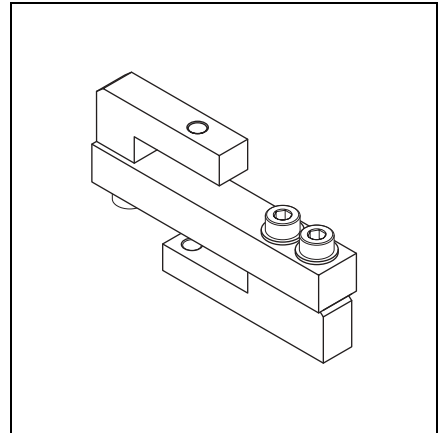

Your weighing specialist

Illustrations are not contractual. Precia-Molen reserves the right to modify at any time, without prior notice, the information contained in this leaflet.

Offices and Factory
 P.O. Box 106 - F 07000 Privas - France
 Tel. 33 (0) 475 664 600
 Fax 33 (0) 475 658 330
 E-MAIL webmaster@preciamolen.com

RCS : 386 620 165 RCS Aubenas

